

# Distortion product otoacoustic emissions as a health surveillance technique for hearing screening in workers in the steel manufacturing industry

M Moepeng, M Soer, B Vinck

Department of Speech-Language Pathology and Audiology, University of Pretoria, Pretoria, 0002, South Africa

Correspondence: Meshack Moepeng, PO Box V6, Ramotswa, Botswana. e-mail: mmoepeng2001@yahoo.co.uk

## ABSTRACT

**Background:** Distortion product otoacoustic emissions (DPOAEs) are a promising screening technique for the early detection of subtle noise-induced cochlear function changes.

**Objectives:** To determine the applicability of DPOAEs as a health surveillance technique for the early detection of noise-induced hearing loss (NIHL) in workers at a steel manufacturing industry.

**Methods:** DPOAE measurements were recorded in 20 participants with no history of occupational noise exposure and 20 participants exposed to noise in the steel manufacturing industry. Participants were not exposed to noise for at least 48 hours prior to testing. All participants were male, with normal audiometric thresholds of  $\leq 15$  dB HL. The DPOAE presence and response levels for different frequencies were compared between the two groups. The study further evaluated the short-term test-retest repeatability of DPOAE measurements.

**Results:** The noise-exposed group had significantly lower DPOAE response amplitudes than the control group for all the tested frequencies:  $p < 0.001$  at 2002 to 4004 Hz;  $p = 0.01$  and  $p = 0.001$  at 6348 and 7996 Hz, respectively, suggesting early outer hair cell damage in the noise-exposed group. DPOAEs showed good reproducibility.

**Conclusion:** DPOAEs appear to be a sensitive technique for detecting noise-induced subtle cochlear function changes. DPOAEs could be used as a health surveillance technique in conjunction with pure tone audiometry for the early detection of NIHL in the steel manufacturing industry.

**Keywords:** Occupational noise exposure, occupational noise-induced hearing loss, cochlear function changes, cochlear damage, outer hair cells

## INTRODUCTION

Noise-induced hearing loss (NIHL) can affect workers negatively on emotional, social and financial levels, with adverse effects on their quality of life. The cost of NIHL compensation could also economically harm the affected organisations.<sup>1</sup> In order to prevent NIHL, it is important to detect noise-induced cochlear function changes as early as possible.<sup>2</sup>

Pure tone audiometry (PTA) is currently the gold standard test used in detecting and monitoring NIHL in different industries, including steel manufacturing factories where the daily noise exposure rate levels are in excess of 85 dB (A).<sup>1,3</sup> Existing NIHL can be easily measured and detected using PTA. However, in detecting subclinical noise-induced cochlear function changes, the sensitivity of PTA is questioned.<sup>1,4,5</sup> PTA measures the integrity of the whole auditory pathway, while NIHL in its early stages starts affecting, primarily, the outer hair cells in the cochlea.<sup>1,6</sup> There are some notable limitations in using PTA as the only hearing screening technique in occupational health surveillance programmes. Hearing damage is only detected when permanent irreversible damage has already occurred; consequently, there is no timely prevention of outer hair cell damage from

occupational noise exposure.<sup>3,7</sup> Moreover, PTA testing is subjective and requires the cooperation of the employee. Therefore, results obtained from uncooperative individuals, who could be presenting with pseudohypacusis for compensation purposes, may be unreliable.<sup>3</sup> It is necessary to have a more sensitive test that can detect cochlear function changes at an early stage before permanent, irreversible noise-induced hearing damage occurs.

Several studies have indicated that otoacoustic emissions (OAEs) could be a more suitable diagnostic tool for the early detection of cochlear function changes from excessive noise exposure, allowing detection of cochlear damage before it is evident through conventional audiometry.<sup>1,8,9</sup> OAEs are low level sounds emitted by the outer hair cells in the cochlea and recorded in the external ear.<sup>10</sup> They are a by-product of outer hair cell electromotility (the cellular basis behind the cochlear amplifier), an active, nonlinear cochlear process largely responsible for producing normal hearing sensitivity and frequency selectivity.<sup>11</sup> OAEs can be used specifically to assess outer hair cell function, and have been found to be very sensitive in showing adverse effects of noise damage on outer hair cells.<sup>8,12</sup> They might

be a promising hearing screening technique for the early detection of NIHL in industrial hearing conservation programmes. Researchers are therefore increasingly proposing the incorporation of OAEs as part of occupational health surveillance hearing screening procedures.<sup>2,3,13</sup>

The two most common clinically used OAEs are transient evoked OAEs (TEOAEs) and distortion product OAEs (DPOAEs).<sup>11,14,15</sup> Both have previously been used to monitor the effects of noise.<sup>8,12,16</sup> DPOAE responses are frequency-specific, reliable, replicable and perform better in high frequencies, and therefore might be suitable for the early detection of NIHL which mostly affects the high frequencies.<sup>5,13</sup> The greatest affected frequency is usually 4 kHz, and at early stages of NIHL the affected frequencies are 3 kHz and above while the lower frequencies usually remain intact.<sup>1</sup> To date, there has been little research on the applicability of DPOAEs as a health surveillance technique in the early detection of noise-induced subtle cochlear function changes amongst workers in the steel manufacturing industry.

The main aim of this study was to determine the applicability of DPOAEs as a health surveillance technique for the early detection of NIHL in subjects working in a steel manufacturing industry. The specific objectives of this study were to evaluate the DPOAE response amplitude levels and to determine the proportion of present DPOAEs in workers in the steel manufacturing industry who are exposed to noise but present with normal audiometric thresholds. The study also assessed the repeatability of DPOAE measurements using a single probe fit paradigm.

## METHODS

### Participants

The study was conducted from March to April 2015, using a cross-sectional study design, in a district hospital in Botswana. Healthy male adults who had normal hearing thresholds ( $\leq 15$  dB HL at all PTA-tested frequencies), normal outer ears, and normal middle ear function; were free from all signs and symptoms of ear disease; and were aged 18 to 55 years, were included in the study. Potential participants were excluded if they had a history of exposure to ototoxic agents, ear infections/discharges, ear surgery, hearing loss, chronic tinnitus, diabetes mellitus, hypertension, tuberculosis, malaria, or history of non-occupational noise exposure.

The noise-exposed group consisted of steel manufacturing factory workers exposed to various types of noise from machines for drilling, grinding, and welding steel fencing material. The general noise exposure levels within this industry are reported to be 85 to 98 dB (A).<sup>17,18</sup> The control group was recruited from the medical staff of a district hospital, with no history of occupational noise exposure.

A structured health assessment questionnaire was completed to rule out any medical or otological conditions that might have affected the auditory system and consequently influenced the DPOAE measurements.<sup>19,20</sup> The questionnaire, which consisted of both open and closed questions, was administered by the researcher (MM) who spoke the same language as the participants.

### Procedures

The noise-exposed group participants stayed away from work for at least 48 hours prior to testing to exclude the effects of temporary threshold shift.<sup>21</sup> An otoscopic examination was performed for each participant prior

to the PTA and DPOAE measurements to rule out any outer/middle ear pathology. Occluding wax was removed before the tests were performed.

### Immittance testing

A Grason-Stadler GSI-38 clinical immittance meter (calibrated 26/11/2014) was used to perform Y-226 Hz tympanometry and obtain ipsi-lateral acoustic reflexes at 0.5, 1, and 2 kHz. Participants with normal tympanograms (Type A; middle ear compliance of 0.3 to 1.5 ml, ear canal volume of 0.6 to 2 ml, and a middle ear pressure of -50 to +50 daPa<sup>22</sup>) and normal acoustic reflex thresholds of 80 to 100 dB HL in both ears proceeded to audiometry.

### Pure tone audiometry

Air conduction PTA was performed using a Grason-Stadler GSI 61 (2-channel) clinical audiometer and TDH-50 headphones. The hearing thresholds were measured at 0.25, 0.5, 1, 2, 3, 4, 6 and 8 kHz in each ear, following the British Society of Audiology's recommended procedure for pure tone audiometry.<sup>23</sup> The audiometric tests for both groups were performed in a double-walled soundproof booth in a hospital. Participants with normal hearing thresholds ( $\leq 15$  dB HL) in both ears proceeded to DPOAE testing.

### DPOAE measurements

The 2f1-f2 DPOAEs were recorded using an Otodynamics analyser (DP Echoport ILO 292, ILO version 6 software). For both groups, DPOAE measurements were performed in a doubled-walled sound-treated room and the ambient noise levels were monitored and maintained at  $\leq 35$  dB (A),<sup>11</sup> using a Bruel and Kjaer type 2232 precision sound level meter.

Two primary tones at frequencies f1 and f2 were presented, simultaneously, at constant stimulus levels, L1=65 dB SPL and L2=55 dB SPL. The f2/f1 ratio was fixed at 1.22. These frequency ratio and stimulus levels have previously been reported to produce robust DPOAEs.<sup>4,11,14,24</sup> The primary tones were presented such that the f2 frequencies corresponded with the audiometric frequencies at 2, 3, 4, 6 and 8 kHz. DPOAEs were recorded using the f2 frequency range from 750 to 8000 Hz, with recordings done at three points per octave.<sup>1,5,25,26</sup> DPOAE frequency analysis was then performed at 2002, 3174, 4004, 6348 and 7996 Hz, as DPOAEs are reported to be more stable over this frequency range.<sup>27</sup> The 2f1-f2 DPOAE response amplitudes (in dB SPL) were recorded as a function of the f2 frequency.<sup>28</sup>

A probe calibration test was performed at the beginning of each session of recordings, using the Otodynamics-supplied 1 cc calibration cavity. For each participant, the DPOAE recordings were repeated four times in one ear without removing the probe tip between measurements. After testing the first ear, a new probe tip was used on the second ear, and the DPOAE recordings were repeated four times, again without removing the probe tip. This single probe fit paradigm has been shown to produce more repeatable and reliable DPOAE responses.<sup>29-32</sup>

The DPOAE response amplitudes for the four repeated recordings were averaged, to give an average DPOAE amplitude value at each stimulus frequency for each ear. Similarly, the DPOAE noise floor levels for the four repeated recordings were averaged, to give an average noise floor level at each specific stimulus frequency for each ear. Only participants with present DPOAEs at at least one of the frequencies,

2002, 3174, 4004, 6348 and 7996 Hz were included in the final analysis. DPOAEs were considered to be present when the average DPOAE response amplitude was  $\geq 6$  dB SPL above the noise floor level.<sup>8</sup>

### Statistical analysis

All statistical analyses were performed using IBM SPSS version 18 software. The DPOAE responses were described and analysed using both descriptive and inferential test statistics. The mean DPOAE response amplitude levels in the control and the noise-exposed groups were compared per frequency using the independent samples two-tailed t-test.<sup>33</sup> The percentage of present DPOAEs for the control and the noise-exposed groups were compared using the chi square test or the Fisher's exact test.<sup>33</sup> Differences in DPOAE response amplitude test-retest repeatability and reliability for the two groups were determined using one-way repeated measures ANOVA and the intraclass correlation coefficient, respectively.<sup>33</sup> All tests results were considered statistically significant at  $p < 0.05$ .<sup>33</sup>

### Ethical considerations

The study was approved by the University of Pretoria Research and Ethics Committee (Ref No: 14336392) and the Botswana Ministry of Health Research Committee (Ref No: PPME-13/18/1 VOL IX (154)). Permission was also obtained from all the relevant authorities.

### RESULTS

The 20 noise-exposed participants had a mean age of  $36.9 \pm 11.5$  years (range 22 to 54 years). The average noise exposure duration was  $10.9 \pm 6.5$  years (range two to 22 years). The 20 control participants had a mean age of  $34.6 \pm 7.5$  years (range 19 to 55 years). The difference in age profile between the two groups was not statistically significant,  $p > 0.05$ . Only 55 % of the noise-exposed participants reported using hearing protection devices (earplugs) consistently.

### PTA testing: mean hearing thresholds

All participants in both groups had normal hearing thresholds ( $\leq 15$  dB HL) at 0.25, 0.5, 1, 2, 3, 4, 6 and 8 kHz. The right and the left ear PTA hearing thresholds for both groups did not differ significantly across all the tested frequencies, therefore their data were combined for further analysis. Figure 1 shows the mean PTA thresholds for the two groups.

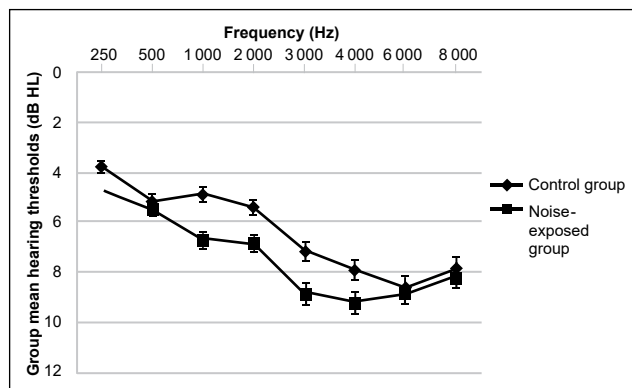

**Figure 1. Mean pure tone audiometry (PTA) hearing thresholds for the control and noise-exposed groups (error bars represent a  $\pm 5\%$  error range for each frequency)**

The mean PTA hearing thresholds for the noise-exposed group were higher than those for the control group across all tested frequencies from 250 Hz to 8 kHz, but the difference between the two groups across all the frequencies was not statistically significant.

### DPOAE testing: response amplitudes

The 2f1-f2 DPOAE response amplitudes in the right and left ears were compared, using a paired samples t-test. For all the five recorded frequencies between 2002 and 7996 Hz, no statistically significant difference in mean response amplitude levels was observed between the right and the left ears ( $p > 0.05$ ), therefore the data were combined for further analysis. Table 1 shows the number of ears with present DPOAEs in the 40 ears of each of the control and the noise exposed groups, as well as the mean DPOAE response amplitudes of ears with present DPOAEs per group, in each of the five recorded frequencies.

**Table 1. Mean DPOAE response amplitudes and the number of ears with present DPOAEs for the control and the noise-exposed groups**

DP-gram Frequency (Hz)	Present DPOAE (N)		DPOAE Amplitude Mean $\pm$ SD (dB SPL)		P-Value
	Control	Noise-exposed	Control	Noise-exposed	
2002	40	38	13.6 $\pm$ 4.5	6.6 $\pm$ 5.9	<0.001
3174	40	33	12.5 $\pm$ 4.5	4.4 $\pm$ 5.1	<0.001
4004	40	26	12.5 $\pm$ 4.1	4.8 $\pm$ 4.4	<0.001
6348	39	8	8.2 $\pm$ 6.5	1.7 $\pm$ 4.0	0.010
7996	32	7	1.1 $\pm$ 5.2	-2.4 $\pm$ 1.1	0.001

Differences in means were compared using the independent samples t-test

The DPOAE response levels for both groups progressively decreased with increasing stimulus frequency. DPOAE response amplitudes were significantly lower in the noise-exposed compared to the control group for all the tested frequencies (Table 1): by 7 dB SPL at 2002 Hz, 8.1 dB SPL at 3174 Hz, 7.7 dB SPL at 4004 Hz, 6.5 dB SPL at 6348 Hz, and 3.5 dB SPL at 7996 Hz.

### DPOAE testing: DPOAE presence

The percentages of present DPOAEs for the two groups are illustrated in Figure 2.

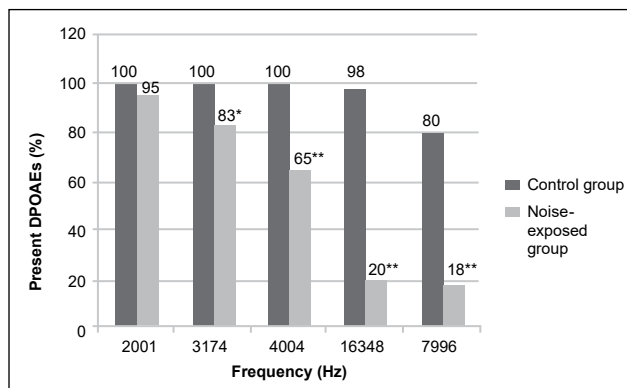

**Figure 2. Percentage of present DPOAEs for the control and noise-exposed groups Fisher's exact test, \* $p < 0.05$ , Chi square test, \*\* $p < 0.001$**

Figure 2 shows a high proportion of present DPOAEs for the control group: 100% for all 40 ears at 2002, 3174 and 4004 Hz, 98% (39 ears) at 6348 Hz, and 80% (32 ears) at 7996 Hz. Conversely, the percentage of present DPOAEs was significantly lower in the noise-exposed group compared to the control group (except at 2002 Hz), and decreased progressively, from 2002 Hz to 7996 Hz.

**DPOAE testing: repeatability and reliability**

Table 2 shows that the DPOAE response levels between the four recordings were not statistically different for the five frequencies. The repeated DPOAE measurements further showed a high degree of reliability as indicated by the intraclass correlation coefficients.

**DISCUSSION**

Several studies have demonstrated that excessive noise exposure may decrease DPOAE response levels.<sup>1,12,34-36</sup> The current study compared the DPOAE response amplitudes between control and noise-exposed participants and found significantly lower DPOAE response amplitudes in the noise-exposed group at all the tested frequencies, from 2002 to 7996 Hz. The largest differences in

**Table 2. Mean DPOAE response amplitudes for the four repeated recordings**

DP-gram Frequency (Hz)	Mean DPOAE response amplitude (dB SPL)				P-Value	Intraclass correlation coefficient (ICC)	95% CI of ICC
	DPOAE Recording						
	1st	2nd	3rd	4th			
2002	10.1	10.1	10.3	10.2	0.31	0.996	0.995 - 0.997
3174	8.7	8.8	8.9	9.0	0.86	0.997	0.995 - 0.998
4004	9.2	9.4	9.6	9.6	0.06	0.993	0.989 - 0.995
6348	6.8	7.1	7.3	7.1	0.11	0.994	0.991 - 0.996
7996	0.5	0.4	0.5	0.6	0.82	0.989	0.982 - 0.994

Mean DPOAE response amplitudes compared using one-way repeated measures ANOVA and intraclass correlation coefficients



**DP Echoport ILO 292 connected to PC, used for DPOAE testing**

*Photograph: Meshack Moepeng*

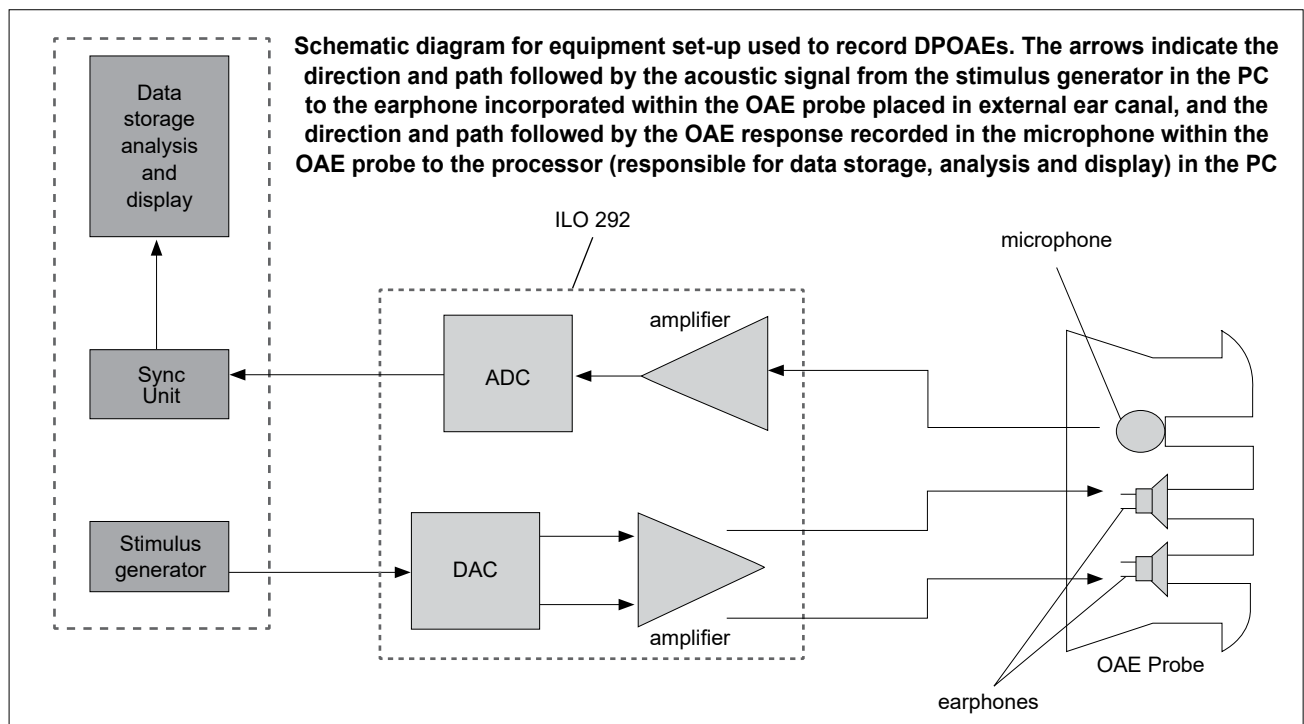

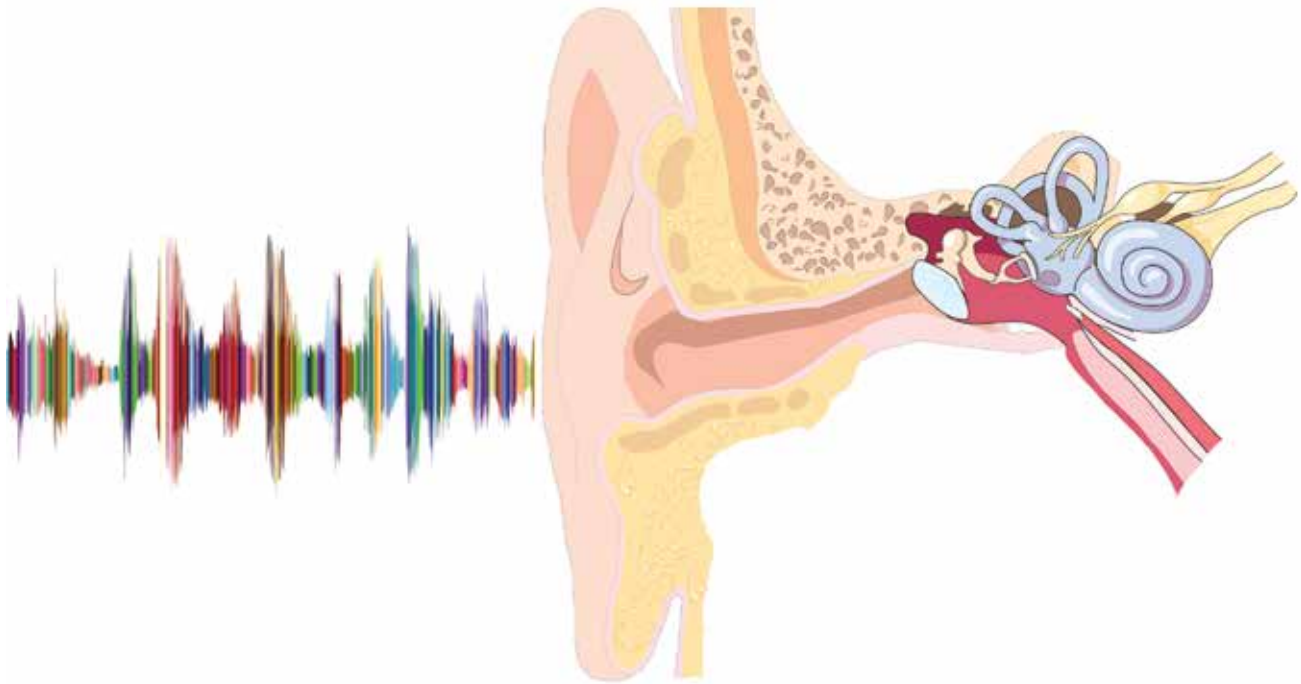

emission levels were observed at 3174 and 4004 Hz, where mean DPOAE response amplitude levels for the noise-exposed group were lower than those for the control group responses by 8.1 and 7.7 dB SPL, respectively. This occurred despite the fact that all the participants had normal audiometric thresholds and the difference in PTA hearing thresholds between the two groups was not statistically significant. Thus, by using DPOAEs, it was possible to detect cochlear damage in the noise-exposed participants before it was evident on the audiogram.<sup>37</sup> These findings suggest that DPOAE testing could be a sensitive test in detecting subtle cochlear function changes due to long-term noise exposure. This is consistent with reports from other studies.<sup>1,5,9,12,16,34</sup>

The smallest DPOAE response amplitude difference of 3.5 dB between the control and the noise-exposed groups was observed at 7996 Hz. This may be an indicator of a marginal effect of noise exposure on cochlear function at this frequency.<sup>38</sup>

Vinck et al.<sup>12</sup> exposed subjects to 90 dB SPL broad band noise for one hour and found that DPOAEs were significantly reduced, while PTA hearing thresholds showed no significant threshold shifts. DPOAEs did not fully recover to the pre-exposure reference levels in the 4 kHz frequency region one hour post exposure. The authors concluded that DPOAEs could be used for the early detection of subtle outer hair cell function changes due to noise exposure. However, there are still different views regarding the applicability of DPOAEs in the early detection of occupational NIHL. Seixas et al.<sup>38</sup> found no evidence to support the use of DPOAEs as a sensitive test for the early detection of noise-induced cochlear damage. This discrepancy could be due to the different study designs used.<sup>12</sup>

The current study further showed a significantly higher percentage of present DPOAEs from 3174 to 7996 Hz in the control group compared to the noise-exposed group. Similar findings have been reported by other studies.<sup>1,5,9,34</sup> This lower percentage of present DPOAEs observed in the noise-exposed group, despite the fact that

all participants had normal audiometric thresholds, further suggests that DPOAEs could be a sensitive test for the detection of subtle cochlear function changes.

The significantly lower DPOAE response amplitude levels across all the frequencies in the noise-exposed group, accompanied by the significantly lower percentage of present DPOAEs evident in most of the frequencies for the same group, even though all participants had normal audiometric thresholds, suggests that DPOAEs could detect early noise-induced outer hair cell damage before it is evident on the audiogram. It appears that DPOAE amplitude reduction or absent DPOAEs could be an early indicator of NIHL even when the audiogram is normal. The reduction in DPOAE amplitude may be an indicator to act to prevent further outer hair cells damage before the pure tone audiogram starts showing some hearing loss.<sup>37</sup>

The study showed that DPOAE measurements are highly reliable and repeatable, in accordance with other studies.<sup>29-32,37</sup> Due to the high test-retest reliability of DPOAEs, some researchers are propounding the applicability of DPOAEs as a health surveillance hearing screening tool in industry.<sup>39,40</sup>

The study findings suggest that detecting subclinical noise-induced cochlear function changes, using either DPOAE amplitude reduction or absent DPOAEs, might be an essential step in preventing irreversible noise-induced cochlear damage in workers in the steel manufacturing industry presenting with normal audiometric hearing thresholds. The findings further support the view that DPOAEs could be used to identify ears with early noise-induced outer hair cell damage that present with normal audiometric thresholds. DPOAEs might be used as a quick, objective tool to assess the status of the cochlea and thereby complement conventional PTA in the early detection of NIHL in the steel manufacturing and other industries.<sup>1,3,16</sup>

#### LIMITATIONS

This study used a small sample size, and the noise-exposure levels

for participants in both groups were not measured. Both these factors could reduce the validity of the results. A cross-sectional study design was used, so the cause-effect relationship between subclinical cochlear function changes and DPOAEs could not be assessed. The inter-test retest reliability of DPOAEs was also not determined.

## RECOMMENDATIONS

Large-scale longitudinal studies, considering different testing environments (e.g. clinical versus industrial settings) and noise-exposure level measurements, are recommended to substantiate the findings from this study. A future study should use age-matched participants with measured noise-exposure levels to further evaluate the relationship between noise-exposure and DPOAE amplitude response levels. Furthermore, the inter-test retest reliability of DPOAEs (fitting, removing and refitting the probe) in the steel manufacturing industry should be investigated.

## CONCLUSION

The findings of the current study suggest that DPOAEs could be a more sensitive test in detecting noise-induced subtle cochlear function changes. DPOAEs could be used as a health surveillance technique to complement PTA in the early detection of NIHL in the steel manufacturing industry.

### LESSONS LEARNED

1. DPOAE amplitude reduction or absent DPOAEs could be an early indicator of NIHL even when the audiogram is normal.
2. DPOAEs could be used as a quick, objective tool for the early detection of noise-induced subtle cochlear function changes in steel manufacturing industry workers.

## REFERENCES

1. Attias J, Horovitz G, El-Hatib N, Nageris B. Detection and clinical diagnosis of noise-induced hearing loss by otoacoustic emissions. *Noise Health*. 2001; 3(12):19-31.
2. Health & Safety Executive. Use of OAE testing in hearing conservation programmes as a Leading Indicator of Damaging Exposure to Noise (LIDEN); an international collaboration, November 2013. Buxton: HSE; 2013.
3. Health & Safety Executive. Report of an international expert symposium on the usefulness of otoacoustic emissions (OAE) testing in occupational health surveillance, 8-9th February 2011. Bootle: HSE; 2011.
4. Marshall L, Lapsley MJA, Heller LM. Distortion-product otoacoustic emissions as a screening tool for noise-induced hearing loss. *Noise Health*. 2001; 3:43-60.
5. Balatsouras DG. The evaluation of noise-induced hearing loss with distortion product otoacoustic emissions. *Med Sci Monit*. 2004; 10(5):218-222.
6. Scientific Committee on Emerging and Newly Identified Health Risks (SCENIHR). Potential health risks of exposure to noise from personal music players and mobile phones including a music playing function. Brussels: European Commission; 2008.
7. Edwards AL, Taela M. Feasibility of screening distortion product otoacoustic emissions to monitor cochlear functioning in noise-exposed mineworkers. *Occup Health Southern Afr*. 2008; 14(1):18-21.
8. Silva VG, Sampaio AL, Oliveira CA, Tauil PL, Jansen GM. Hair cell alteration prevalence rates in students of a school in Distrito Federal. *Braz J Otorhinolaryngol*. 2012; 78(4):91-97.
9. Vinodh RS, Veeranna N. Evaluation of acoustic shock induced early hearing loss with audiometer and distortion product otoacoustic emissions. *Indian J Med Sci*. 2010; 64(3):132-139.
10. Kemp DT. Stimulated acoustic emissions from within the human auditory system. *J Acoust Soc Am*. 1978; 64:1386-1391.
11. Kemp DT. Otoacoustic emissions, their origin in cochlear function, and use. *Br Med Bull*. 2002; 63(1):223-241.
12. Vinck BM, Van Cauwenberge PB, Leroy L, Corthals P. Sensitivity of transient evoked and distortion product otoacoustic emissions to the direct effects of noise on the human cochlea. *Audiology*. 1999; 38:44-52.
13. Edwards A, Van Coller P, Badenhorst C. Early identification of noise-induced hearing loss: a pilot study on the use of distortion product otoacoustic emissions as an adjunct to screening audiometry in the mining industry. *Occup Health Southern Afr*. 2010; 16(4):28-35.
14. Hall JW III. Handbook of otoacoustic emissions. San Diego: Thompson Learning, Singular Publishing Group, Inc.; 2000.
15. Probst R, Harris FP, Hauser R. Clinical monitoring using otoacoustic emissions. *Br J Audiol*. 1993; 27(2):85-90.
16. Job A, Raynal M, Kossowski M, Studler M, Ghernaoui C, Baffioni-venturi A, et al. Otoacoustic detection of risk of early hearing loss in ears with normal audiograms: a 3-year follow-up study. *Hear Res*. 2009; 251(1):10-16.
17. Singh LP, Bhardwaj A, Kumar DK. Prevalence of permanent hearing threshold shift among workers of Indian iron and steel small and medium enterprises: A study. *Noise Health*. 2012; 14:119-128.
18. Tersoo TM, Dawodu OM, Babakatcha N. Assessment of the level of noise produced by sound generating machines in Lapai, Northern Nigeria. *Adv Appl Sci Res*. 2011; 2(6):520-531.
19. Kei J, Brazel B, Crebbin K, Richards A, Willeston N. High frequency distortion product otoacoustic emissions in children with and without middle ear dysfunction. *Int J Pediatr Otorhinolaryngol*. 2007; 71(1):125-133.
20. Reavis KM, McMillan G, Austin D, Gallun F, Fausti SA, Gordon JS, et al. Distortion-product otoacoustic emission test performance for ototoxicity monitoring. *Ear Hear*. 2011; 32(1):61-74.
21. Kirchner DB, Evenson E, Dobie RA, Rabinowitz P, Crawford J, Kopke R, et al. Occupational noise-induced hearing loss. *J Occup Environ Med*. 2012; 54(1):106-108.
22. Shanks J, Shohet J. Tympanometry in clinical practice. In: Katz J, editor. Handbook of clinical audiology. 6th ed. Philadelphia: Lippincott, Williams & Wilkins; 2009. pp. 157-188.
23. British Society of Audiology. Recommended procedure: Pure-tone air-conduction and bone-conduction threshold audiometry with and without masking. Reading: British Society of Audiology; 2011.
24. Ziarani AK, Konrad A. A novel method of estimation of DPOAE signals. *IEEE Trans Biomed Eng*. 2004; 51(5):864-868.
25. Poole K. Optimum test conditions and variability of otoacoustic emission testing in individuals with normal hearing (RR840). Buxton: HSE Books; 2011.
26. Ramos JA, Kristensen SGB, Beck DL. An overview of OAEs and normative data for DPOAEs. *Hearing Review*. 2013; 20(11):30-33.
27. Hoshino M, Ueda H, Nakata S. Long-term stability between click-evoked otoacoustic emissions and distortion product otoacoustic emissions in guinea pigs: a comparison. *ORL J Otorhinolaryngol Relat Spec*. 1999; 61(4):175-180.
28. Grabham NJ, Swabey MA, Chambers P, Lutman ME, White NM, Chad JE, et al. An evaluation of otoacoustic emissions as a biometric. *IEEE Transactions on Information Forensics and Security*. 2013; 8:174-183.
29. Keppler H, Dhooge I, Maes L, D'haenens W, Bocksteal A, Philips B, et al. Transient-evoked and distortion product otoacoustic emissions: a short-term test-retest reliability study. *Int J Audiol*. 2010; 49:99-109.
30. Valero MD, Ratnam R. Reliability of distortion-product otoacoustic emissions in the common marmoset (*Callithrix jacchus*). *Hear Res*. 2011; 282(1-2):265-271.
31. Wagner W, Heppelmann G, Vonthein R, Zenner HP. Test-retest repeatability of distortion product otoacoustic emissions. *Ear Hear*. 2008; 29(3):378-391.
32. Zhao F, Stephens D. Test-retest variability of distortion-product otoacoustic emissions in human ears with normal hearing. *Scand. Audiol*. 1999; 28:171-178.
33. Field A. Discovering statistics using SPSS. London: SAGE Publications Ltd; 2009.
34. Atcharyasathian V, Chayarpham S, Saekhow S. Evaluation of noise-induced hearing loss with audiometer and distortion product otoacoustic emissions. *J Med Assoc Thai*. 2008; 91(7):1066-1071.
35. Guida HL, Morini RG, Cardoso ACV. Audiologic and otoacoustic emission evaluation in individuals exposed to noise and plaguicides. *Int Arch Otorhinolaryngol*. 2009; 13(3):264-269.
36. Korres GS, Balatsouras DG, Tzagaroulakis A, Kandiloros D, Ferekidou E, Korres S. Distortion product otoacoustic emissions in an industrial setting. *Noise Health*. 2009; 11(43):103-110.
37. Jaffer S, Razi MS. Hearing loss in walkman users. *J Occup Safety Health*. 2004; 1:31-37.
38. Seixas NS, Neitzel R, Stover B, Sheppard L, Feeney P, Mills D, et al. 10-Year prospective study of noise exposure and hearing damage among construction workers. *Occup Environ Med*. 2012; 69(9):643-650.
39. Prasher D, Sulkowski W. The role of otoacoustic emissions in screening and evaluation of noise damage. *Int J Occup Med Environ Health*. 1999; 12:183-192.
40. Seixas NS, Goldman B, Sheppard L, Neitzel R, Norton S, Kujawa SG. Prospective noise-induced changes to hearing among construction industry apprentices. *Occup Environ Med*. 2005; 62:309-317.